

4

3

2

1

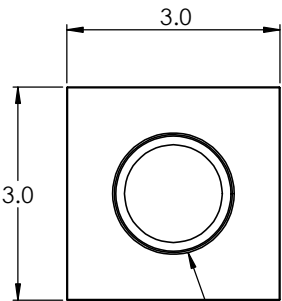
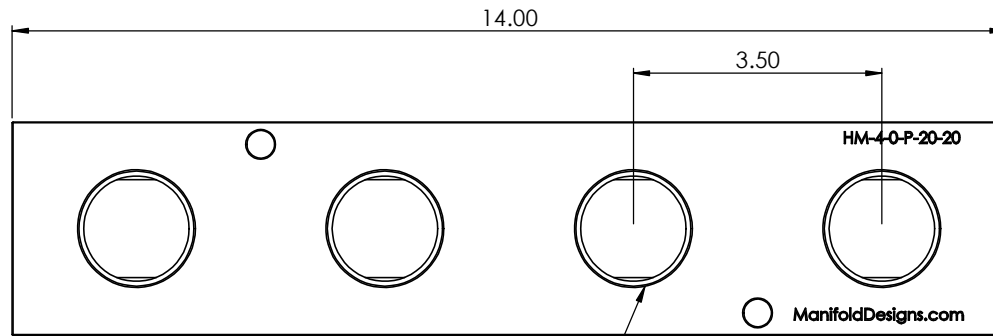
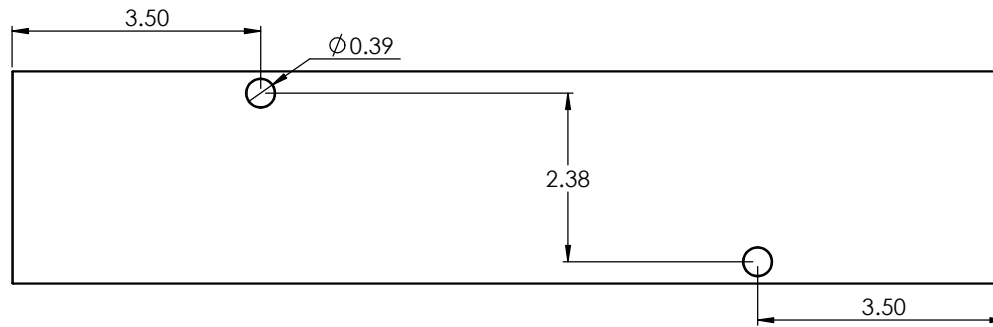

1-1/4 NPT Both Ends

1-1/4 NPT Typ Face

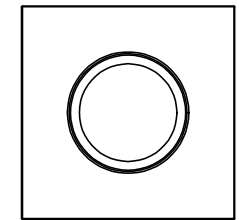

Manifold Design & Production Inc.

**PROPRIETARY AND CONFIDENTIAL**  
 THE INFORMATION CONTAINED IN THIS DRAWING IS THE SOLE PROPERTY OF <INSERT COMPANY NAME HERE>. ANY REPRODUCTION IN PART OR AS A WHOLE WITHOUT THE WRITTEN PERMISSION OF <INSERT COMPANY NAME HERE> IS PROHIBITED.

		UNLESS OTHERWISE SPECIFIED:	NAME	DATE	TITLE: <h1>Header Manifold</h1>
		DIMENSIONS ARE IN INCHES	DRAWN		
		TOLERANCES:	CHECKED		
		FRACTIONAL: ±	ENG APPR.		
		ANGULAR: MACH ± BEND ±	MFG APPR.		Q.A. COMMENTS:
		TWO PLACE DECIMAL ±			
		THREE PLACE DECIMAL ±			SIZE DWG. NO. REV <b>B</b> HM-4-0-P-20-20
NEXT ASSY	USED ON	MATERIAL	SCALE: 1:1 WEIGHT: SHEET 1 OF 1		
APPLICATION		6061			
		FINISH			
		Black Anodize			
		DO NOT SCALE DRAWING			

4

3

2

1